

# OPERATOR O & M MANUAL

## ROS 250- 2000



# INTRODUCTION

Your ROS commercial reverse osmosis system is a durable piece of equipment, with proper care will last for many years. This User's Manual outlines installation, operation, maintenance, and troubleshooting contains details vital to the sustained performance of your system.

If your system is altered at the site of operation or if the feed water conditions change, contact your local dealer or distributor to determine the proper recovery for your application. NOTE: In order to maintain warranty, an operating log must be maintained. Copies must be sent to your local dealer or distributor.

NOTE: The User's Manual must be read and fully understood prior to operating or servicing the reverse osmosis system. Keep the manual and other associated information for future reference and for new operators or qualified personnel near the system.

## Safety



Warning

**READ THE ENTIRE MANUAL BEFORE PROCEEDING. FAILURE TO FOLLOW ANY INSTRUCTIONS OR OPERATING PARAMETERS MAY LEAD TO SYSTEM FAILURE OR PERSONAL INJURY.**

- DO NOT USE WITH MICRO-BIOLOGICALLY UNSAFE WATER OR OF UNKNOWN QUALITY WITHOUT ADEQUATE DISINFECTION.
- OXIDIZING CHEMICALS AND GASSES MUST BE REMOVED TO AVOID DAMAGING THE MEMBRANES.
- ALWAYS TURN OFF THE UNIT, DEPRESSURIZE THE FEED WATER, AND DISCONNECT THE ELECTRICAL POWER WHEN WORKING ON THE UNIT.
- NEVER ALLOW THE PUMP TO RUN DRY.
- NEVER OPERATE THE SYSTEM WITH THE CONCENTRATE VALVE CLOSED.
- NEVER ALLOW THE UNIT TO FREEZE OR OPERATE WITH A FEED WATER TEMPERATURE ABOVE 90°F.

The User's Manual outlines various safety headings used throughout this manual's text and are enhanced and defined below:

**NOTE:** Indicates statements that provide further information and clarification.

**CAUTION:** Indicates statements that are used to identify conditions or practices that could result in equipment or other property damage.

**WARNING:** Indicates statements that are used to identify conditions or practices that could result in injury or loss of life.

**FAILURE TO FOLLOW WARNINGS COULD RESULT IN SERIOUS INJURY OR EVEN DEATH.**

## Labeling

- Do not under any circumstance; remove any Caution, Warning, or other descriptive labels from the system.

# SYSTEM REQUIREMENTS AND OPERATION GUIDELINES

## INSTALLATION INSTRUCTIONS

- Proper pretreatment must be determined and installed prior to the system.
- The water supply and pretreatment equipment should be sufficient to provide a minimum of 45 psi at the maximum feed flow.
- Responsibility for meeting local electrical and plumbing codes lies with the owner/operator.
- Install indoors in an area protected from freezing. Space allowances for the removal of the membranes from the pressure vessels should be provided.

## PLUMBING CONNECTIONS

**NOTE:** It is the responsibility of the user to ensure the installation is done according to local codes and regulations.

1. Connect the feed water line to the inlet solenoid valve. A feed water shutoff valve should be located within 10 feet of the system.
2. Temporarily connect the product water outlet to a drain. The product outlet is located on the permeate flow meter.
3. Connect the concentrate water outlet to a drain. The concentrate outlet is located on the concentrate flow meter. The concentrate drain line should never be restricted. An air gap must be located between the end of the drain line and the drain.

## ELECTRICAL CONNECTIONS

**NOTE:** It is the responsibility of the user to ensure that the installation is done by a licensed electrician according to local codes and regulations.



Warning

**WARNING:**

**To reduce the risk of electrical shock, the incoming power supply must include a protective earth ground.**

1. Make sure the power to the system is off.
2. Wire the supplied power cord with the appropriate voltage and phase (dependent on system being installed) to a junction box power supply with a suitable breaker following local electrical codes.

The pumps and motors used are vane pumps with O.D.P. Carbonator motor combinations. Follow these guidelines to ensure proper operation of the pump:

- The pump must NEVER be run dry. Operating the pump without sufficient feed water will damage the pump.
- ALWAYS feed the pump with filtered water. The pump is susceptible to damage from sediment and debris.

# Float Switch Addition

Step 1. Locate The high-pressure switch labeled as “High Press Switch”



ROS (Rear View)

Step 2. Remove Cover using Philips screwdriver

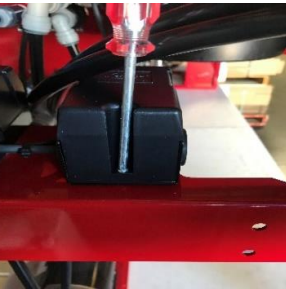

Step 3. Remove Red and White wires from switch, cut terminals and strip wire 1/4” -1/2”



Step 4. Cut opening on rubber bushing to allow float switch wire to pass through,



Step 5. Splice one float wire together with red wire. Connect second float wire to remaining white wire. Replace cover.

*Caution: Only use Reverse Acting sump pump floats. No voltage should be applied or computer failure will occur.*

# STARTUP PROCEDURES

Carefully inspect your system before start-up. Check all plumbing and electrical connections. A User's Manual, and a Filter Housing Wrench are included with your reverse osmosis system

## INITIAL STARTUP:

1. Open the Bypass valve on the pump, flush with body.
2. Fully open the Concentrate Valve on the Concentrate Flow Meter.
3. Fully close the Concentrate Recirculate Valve on the Concentrate Recirculate Flow Meter.
4. Press the Power button on the controller.
5. Allow the unit to run for 10-15 minutes to flush the preservative from the membrane(s).

**NOTE:** Do not exceed 150 psi on the Pump Pressure Gauge.

6. Adjust the Concentrate Valve, Concentrate Recycle Valve and Pump Valve until the desired flows are achieved.
7. Allow the product water to flow to drain for an additional 15 minutes.
8. Test and verify unit performance. Turn off the system and re-direct the product line to the point of use.
9. Restart the system and check for leaks.



- DO NOT USE WHERE THE WATER IS MICRO-BIOLOGICALLY UNSAFE OR OF UNKNOWN QUALITY WITHOUT ADEQUATE DISINFECTION BEFORE OR AFTER THE SYSTEM.
- PRETREATMENT MUST BE SUFFICIENT TO ELIMINATE CHEMICALS THAT WOULD ATTACK THE MEMBRANE MATERIALS.
- ALWAYS TURN OFF THE UNIT, SHUT OFF THE FEED WATER, AND DISCONNECT THE ELECTRICAL POWER WHEN WORKING ON THE UNIT.
- NEVER ALLOW THE PUMP TO RUN DRY.
- NEVER OPERATE THE SYSTEM WITH THE CONCENTRATE VALVE CLOSED.
- NEVER ALLOW THE UNIT TO FREEZE OR OPERATE WITH A FEED WATER TEMPERATURE ABOVE 100°F.

# Installation and Start Up Checklist

## STARTUP CONDITIONS

Installation Date: \_\_\_\_\_

Installer Name: \_\_\_\_\_

Site of Install: \_\_\_\_\_

System Model: \_\_\_\_\_

Water Source: \_\_\_\_\_

Pre-treatment Installed:  Yes  No

If yes, explain: \_\_\_\_\_

### FEED WATER ANALYSIS

TDS: Design \_\_\_\_\_ Startup \_\_\_\_\_

Turbidity: \_\_\_\_\_

Total Iron: \_\_\_\_\_

Chlorine: \_\_\_\_\_

Hardness: \_\_\_\_\_

Feed Water Temp: \_\_\_\_\_

Pre-filter Cartridge Model: \_\_\_\_\_

Starting Pre-filter Inlet Pressure: \_\_\_\_\_

- Pressure at Startup: \_\_\_\_\_

### FLOW METER READINGS

• **Concentrate** Design \_\_\_\_\_ Startup \_\_\_\_\_

• **Recycle** Design \_\_\_\_\_ Startup \_\_\_\_\_

• **Permeate** Design \_\_\_\_\_ Startup \_\_\_\_\_

\_\_\_\_\_  
(Installer signature)

\_\_\_\_\_  
(date)

## INSTALLATION CHECKLIST

Installation Address: \_\_\_\_\_

- Pre-treatment installed, flushed and working.
- Installation location allows access to membrane(s).
- Listed components and fittings are present.
- Loose components assembled to system.
- Membranes and pre-filter installed.
- System fastened securely in place.
- Plumbing connections are complete.
- Initial flush without leaks.
- Electrical power connected, single phase. \_\_\_Volts \_\_\_Hz
- System sanitized.
- Controller operational.
- Proper operation is verified.
- All checks above have been completed.

### INSTALLATION NOTES:

\_\_\_\_\_  
\_\_\_\_\_  
\_\_\_\_\_  
\_\_\_\_\_  
\_\_\_\_\_  
\_\_\_\_\_  
\_\_\_\_\_  
\_\_\_\_\_  
\_\_\_\_\_  
\_\_\_\_\_

# MEMBRANE SPECIFICATIONS

## Operating Limits

Membrane Type	Polyamide Thin-Film Composite
Maximum Operating Temperature	100° F (38° C)
Maximum Operating Pressure	225 psi (15 .5 bar) System Limits
pH Range, Continuous Operation*	2–11
pH Range, Short Term Cleaning (30 min)	1–13
Maximum Feed Silt Density Index	5
Chlorine Tolerance	0 ppm

\*Maximum temperature for continuous operations above pH 10 is 95° F (35° C)

### ROS 250 100-2521 Membrane - Product Specifications

Part Number	Description	Applied Pressure psi (bar)	Permeate Flow Rate gpd (m3/d)	Nominal Salt Rejection (%)	Membrane Quantity
95606	100 – 2521	100 (6.89)	400 (1.51)	98.5	1

### ROS 500 100-2521 Membrane - Product Specifications

Part Number	Description	Applied Pressure psi (bar)	Permeate Flow Rate gpd (m3/d)	Nominal Salt Rejection (%)	Membrane Quantity
95606	100 – 2521	100 (6.89)	400 (1.51)	98.5	2

### ROS 1000 100-4021 Membrane - Product Specifications

Part Number	Description	Applied Pressure psi (bar)	Permeate Flow Rate gpd (m3/d)	Nominal Salt Rejection (%)	Membrane Quantity
95609	100 – 4021	100 (6.89)	1000 (3.76)	98.5	1

### ROS 2000 100-4021 Membrane - Product Specifications

Part Number	Description	Applied Pressure psi (bar)	Permeate Flow Rate gpd (m3/d)	Nominal Salt Rejection (%)	Membrane Quantity
95609	100 – 4021	100 (6.89)	1000 (3.76)	98.5	2

Under certain conditions, the presence of free chlorine and other oxidizing agents will cause premature membrane failure. Since oxidation damage is not covered under warranty, the manufacturer recommends removing residual free chlorine by pretreatment prior to membrane exposure. Wet tested membrane elements must be kept sealed and moist when in storage. Drying out may occur and damage the membrane permanently. Prevent elements from freezing or being exposed to direct sunlight. Wet tested elements are vacuum sealed in a polyethylene bag containing Membrane Preservation and then packaged in a cardboard box. Discard the permeate for the first 24 hours of operation. The permeate flow (product water flow) varies with feed water temperature. For membrane warranty information, please contact the manufacturer.

The manufacturer believes the information and data contained herein to be accurate and useful. The information and data are offered in good faith, but without guarantee, as conditions and methods of use of products are beyond the manufacturer's control. The manufacturer assumes no liability for results obtained or damages incurred through the application of the presented information and data. It is the user's responsibility to determine the appropriateness of these products for the user's specific end use.

# SYSTEM IDENTIFICATION

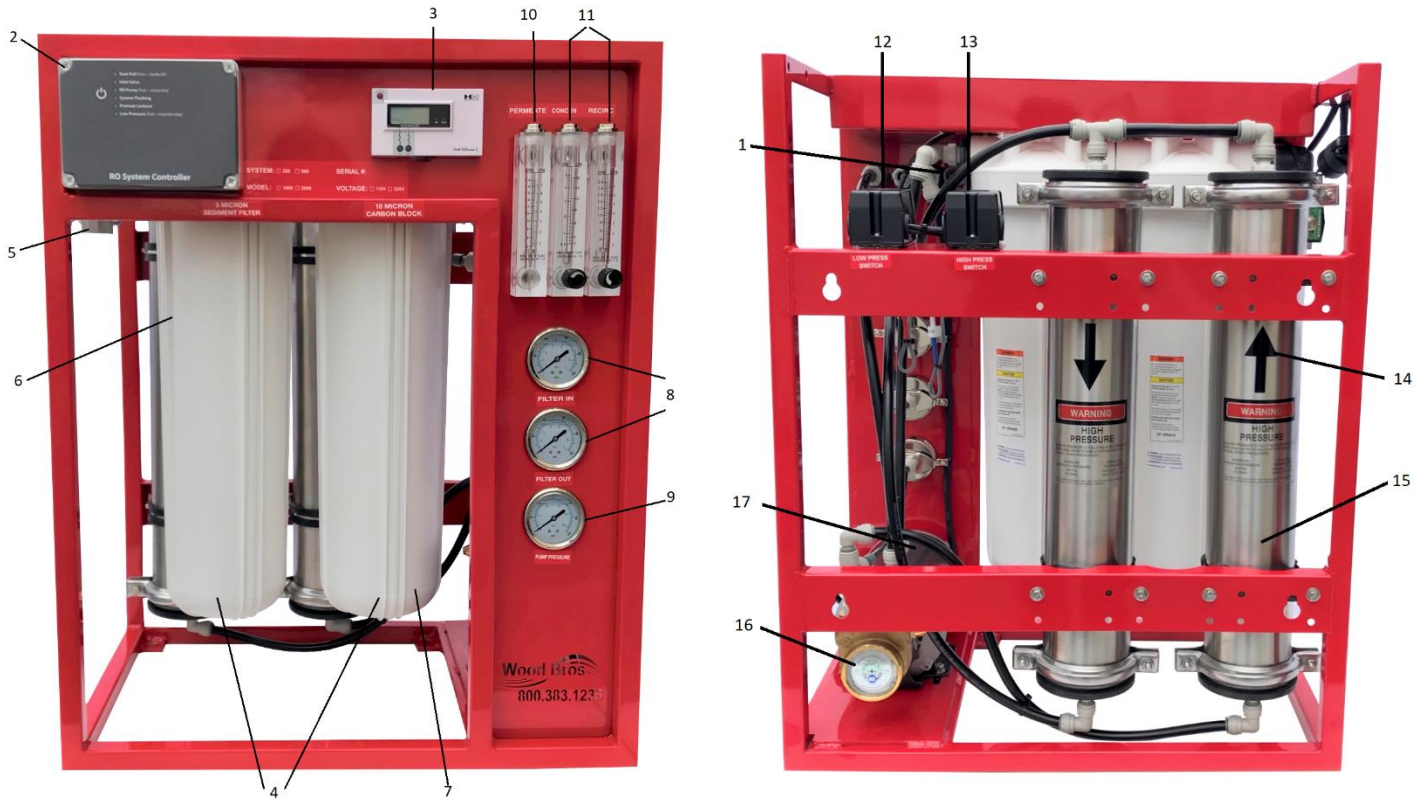

Models: ROS 250-500

Item No.	Description	Part No.	ROS-250	ROS-500
1	CHECK VALVE, 693 SERIES, PP, 3/8" FNPT X 3/8" FNPT, SMC	10071	1	1
2	CONTROLLER, COMPUTER, CHIP, 110V 1 PHASE, ICONROLS	80046	1	1
3	HM DIGITAL, DM-2, DUAL TDS MONITOR WITH 1/4" T-FITTINGS	10008	1	1
4	FILTER, HOUSING, BLK/WHT, 4.5" X 10", N/PR, 3/4"FNPT	14017	2	2
5	SOLENOID VALVE, STAINLESS STEEL, N/C, 3/4"FNPT, 110V, IP65	40104	1	1
6	FILTER, POLYPROPYLENE, 4.5" X 10" 5 MICRON	30007	1	1
7	CARBON, BLOCK, 4.5" X 10", 10 MICRON	20006	1	1
8	PANEL MOUNT, GLYC FILL, GAUGE, 0-100 PSI, 2.5", 1/4" MNPT	40001	2	2
9	PANEL MOUNT, GLYC FILL, GAUGE, 0-300 PSI, 2.5", 1/4" MNPT	40002	1	1
10	PANEL MOUNT, FLOW METER, 0.1-1 GPM, SS, 1/2" MNPT X 1/4" FNPT	40010	1	1
11	PANEL MOUNT, FLOW METER, SS VALVE, 0.1-1 GPM, 1/2" MNPT x 1/4" FNPT	40030	2	2
12	DWYERS, CXA-R1, LOW, PRESSURE SWITCH, N/O, 15/30PSIG, 110V/220V	40110	1	1
13	DWYERS, CXA-S1, HIGH, PRESSURE SWITCH, N/C, 30-40PSIG, 110V/220V	40111	1	1
14	MEMBRANE, 100, 2521, DRY, WOOD BROS	95606	1	2
15	MEMBRANE, HOUSING, 304, SS, 2521, 3/8" P X 3/8" C FNPT	40061	1	2
16	PUMP, LOW LEAD BRASS, BYPASS, 2.3GPM, PA401X	80001	1	1
17	MOTOR, CARBONATOR, 1/3 HP, 115/230, 50/60HZ, 48Y	80020	1	1



# SYSTEM IDENTIFICATION

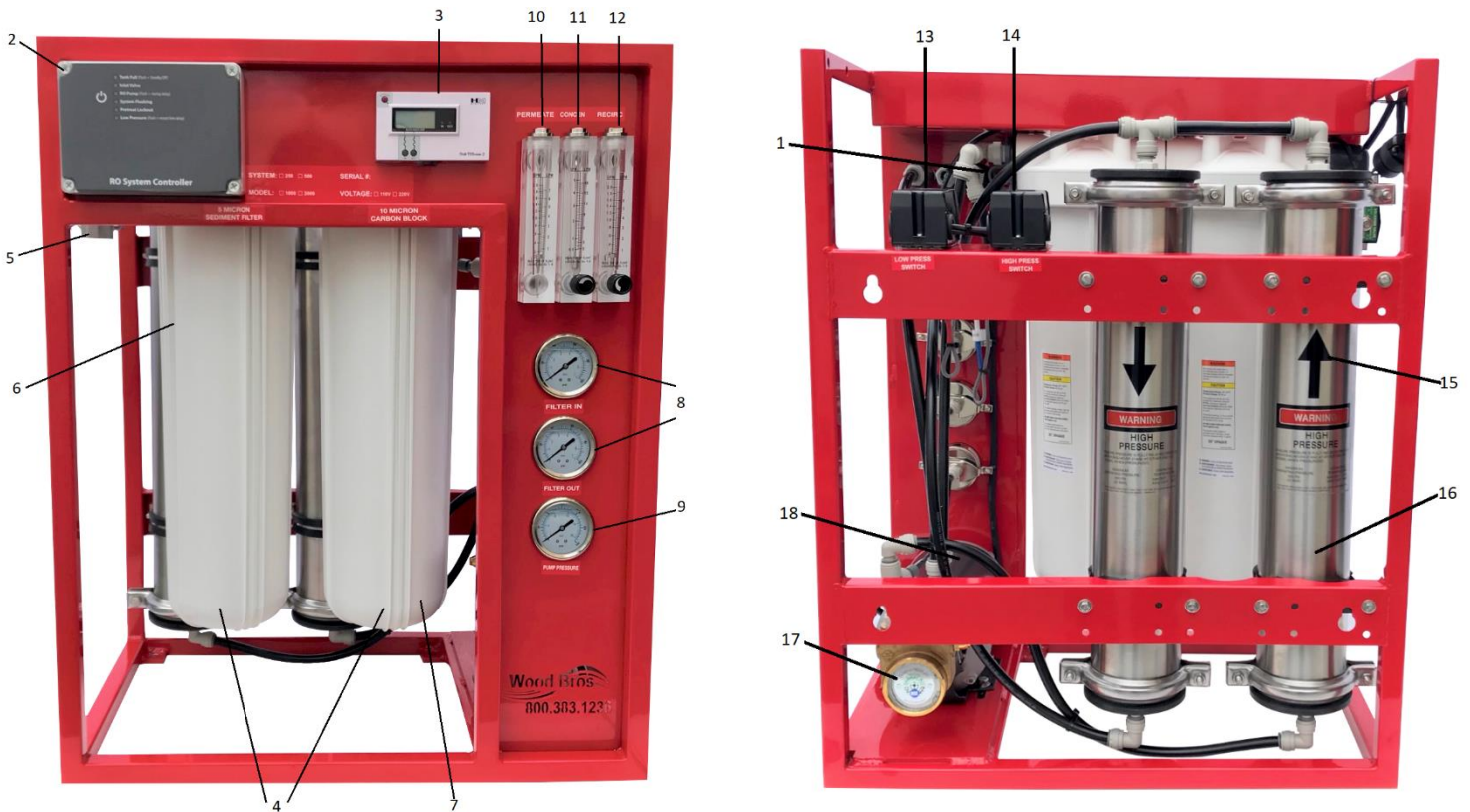

Models: ROS 1000-2000

Item No.	Description	Part No.	ROS-1000	ROS-2000
1	CHECK VALVE, 685 SERIES, PP, 1/2" FNPT X 1/2" FNPT, SMC	10016	1	1
2	CONTROLLER, COMPUTER, CHIP, 110V 1 PHASE, ICONTROLS	80046	1	1
3	HM DIGITAL, DM-2, DUAL TDS MONITOR WITH 1/4" T-FITTINGS	10008	1	1
4	FILTER, HOUSING, BLK/WHT, 4.5" X 20", N/PR, 3/4" FNPT	14018	2	2
5	SOLENOID VALVE, STAINLESS STEEL, N/C, 3/4" FNPT, 110V, IP65	40104	1	1
6	FILTER, POLYPROPYLENE, 4.5" X 20" 5 MICRON	30017	1	1
7	CARBON, BLOCK, 4.5" X 20", 10 MICRON	20012	1	1
8	PANEL MOUNT, GLYC FILL, GAUGE, 0-100 PSI, 2.5", 1/4" MNPT	40001	2	2
9	PANEL MOUNT, GLYC FILL, GAUGE, 0-300 PSI, 2.5", 1/4" MNPT	40002	1	1
10	PANEL MOUNT, FLOW METER, 0.2-2 GPM, SS, 1/2" MNPT X 1/4" FNPT	40011	1	1
11	PANEL MOUNT, FLOW METER, SS VALVE, 0.5-5 GPM, 1/2" MNPT X 1/4" FNPT	40032	1	1
12	PANEL MOUNT, FLOW METER, SS VALVE, 0.2-2 GPM, 1/2" MNPT X 1/4" FNPT	40031	1	1
13	DWYERS, CXA-R1, LOW, PRESSURE SWITCH, N/O, 15/30PSIG, 110V/220V	40110	1	1
14	DWYERS, CXA-S1, HIGH, PRESSURE SWITCH, N/C, 30-40PSIG, 110V/220V	40111	1	1
15	MEMBRANE, HOUSING, 304, SS, 4021, 1/2" P X 1/2" C FNPT	40064	1	2
16	MEMBRANE, 100, 4021, DRY, WOOD BROS	95609	1	2
17	PUMP, LOW LEAD BRASS, BYPASS, 5.3GPM, PA1001	80003	1	1
18	MOTOR, CARBONATOR, 3/4 HP, 115/230, 50/60HZ, 48Y	80022	1	1

## OPERATION AND MAINTENANCE

The reverse osmosis process causes the concentration of impurities. The impurities may precipitate (come out of solution) when their concentration reaches saturation levels.

**NOTE: Precipitation can scale or foul membranes and must be prevented.**

Check your feed water chemistry and pre-treat the water and/or reduce the system's recovery as required.

### **PRE-FILTER PRESSURE GAUGES:**

Pre-Filter gauges measure the feed water pressure when it enters and exits the pre-filters. A pressure differential of 15psi or more on the two pressure gauges indicates the pre-filter requires servicing. **Failure to maintain the filter will result in system damages.**

### **CHANGING THE PRE-FILTER:**



Warning

**WARNING: All pressure gauges must read zero before proceeding. Before attempting, disconnect the power from the system and bleed all water pressure from the system.**

*The system comes with a standard 5 Micron Sediment Filter that is located inside the filter housing.*

1. To remove filter, turn the filter housing counter clockwise using the filter wrench supplied with system.
2. Once removed, replace the sediment cartridge with a similar size 5-micron sediment filter. Dispose of the old filter properly. Check the O-ring located at the top of the filter housing and re-lube or replace if necessary. Re-install housing, turn **hand tight** (clockwise) and check for leaks after system is turned back on.

### **MEMBRANE INSTALLATION, REMOVAL AND REPLACEMENT:**

Installing and replacing membranes: Please refer to the following instructions when removing and replacing membrane elements.



Warning

**WARNING: All pressure gauges must read zero before proceeding. Before attempting, disconnect the power from the system and bleed all water pressure from the system.**

1. Remove the end plugs from the top of the pressure vessels. This is done by removing the two half-clamps retaining the plugs on either end; the end plugs should then freely slide out of the pressure vessel.
2. Remove the replacement membrane element(s) from the shipping box; the membrane(s) should be contained within a plastic oxygen barrier bag.
3. Cut the bag open as close as possible to the seal at one end of the bag, so the bag may be re-used if necessary.

**NOTE:** Wear gloves for the following steps in order not to contaminate the membrane.

4. Remove membrane from bag. Make sure that all parts of the membrane are clean and free from dirt. Examine the brine seal and permeate tube for nicks or cuts. Replace the O-rings or brine seal if damaged.
5. Load membranes into pressure vessels according to the concentrate flow direction. Note the position of the brine seal placement on the membrane. The brine seal must be at the water inlet of the housing.
6. Use non-petroleum-based silicone grease on the O-rings and brine seal before installing the membrane.
7. Install the new membrane in directions as shown in diagram:

**NOTE:** HOUSING PLACEMENT ON ALL MODELS FOLLOW THE BELOW DIAGRAM. MODELS WITH ONLY ONE HOUSING PLACEMENT (ROS-250, ROS-1000), PLEASE REFER TO MEMBRANE PLACEMENT ON RIGHT.

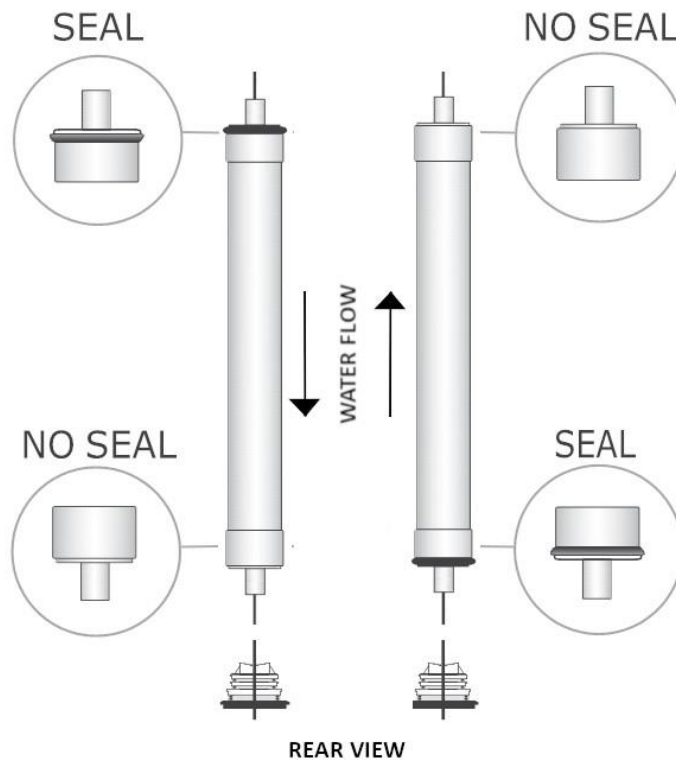

8. Once membrane has been fully inserted into vessel, re-install the black end plug and the two half clamps. (Ensure the clamps are fully seated all the way around the end plug.)
9. Change is complete.

# TROUBLESHOOTING GUIDE

<b>1. Low inlet pressure</b>	A. Low supply pressure	A. Increase inlet pressure
	B. Cartridge filters plugged	B. Change filters
	C. Solenoid valve malfunction	C. Replace solenoid valve and/or coil
	D. Leaks	D. Fix any visible leaks
<b>2. Low permeate flow</b>	A. Low inlet flow	A. Adjust concentrate valve
	B. Cold feed water	B. See temperature correction sheet (page 12)
	C. Low operating pressure	C. See low inlet pressure
	D. Defective membrane brine seal	D. Inspect and/or replace brine seal
	E. Fouled or scaled membrane	E. Clean membranes
<b>3. High permeate flow</b>	A. Damaged product tube O-rings	A. Inspect and/or replace O-rings
	B. Damaged or oxidized membranes	B. Replace membrane(s)
	C. Exceeding maximum feed water temperature	C. See temperature correction sheet (page 12)
<b>4. Poor permeate quality</b>	A. Low operating pressure	A. See low inlet pressure
	B. Damaged product tube O-rings	B. Inspect and/or replace O-rings
	C. Damaged or oxidized membranes	C. Replace membrane(s)
<b>5. Membrane fouling</b>	A. Metal oxide fouling	A. Improve pretreatment for colloid removal. Clean with acid cleaners.
	B. Colloidal fouling	B. Optimize pretreatment for colloid removal. Clean with high pH anionic cleaners.
	C. Scaling (CaSO <sub>4</sub> , CaSO <sub>3</sub> , BaSO <sub>4</sub> , SiO <sub>2</sub> )	C. Increase acid addition and antiscalant dosage for CaVO <sub>3</sub> and CaCO <sub>4</sub> . Reduces recovery. Clean with acid cleaners.
	D. Biological fouling	D. Shock dosage of Sodium Bisulfate. Continuous feed of Sodium Bisulfate at reduced pH Chlorination and de-chlorination. Replace cartridge filters.
	E. Organic fouling	E. Activated carbon or another pretreatment. Clean with high pH cleaner.
	F. Chlorine oxidation	F. Check chlorine feed equipment and de-chlorination system.
	G. Abrasion of membrane by crystalline material	G. Improve pretreatment. Check all filters for media leakage.

# ELECTRICAL DRAWING – 110/220 VOLT

